

Plan for Sliding Gate

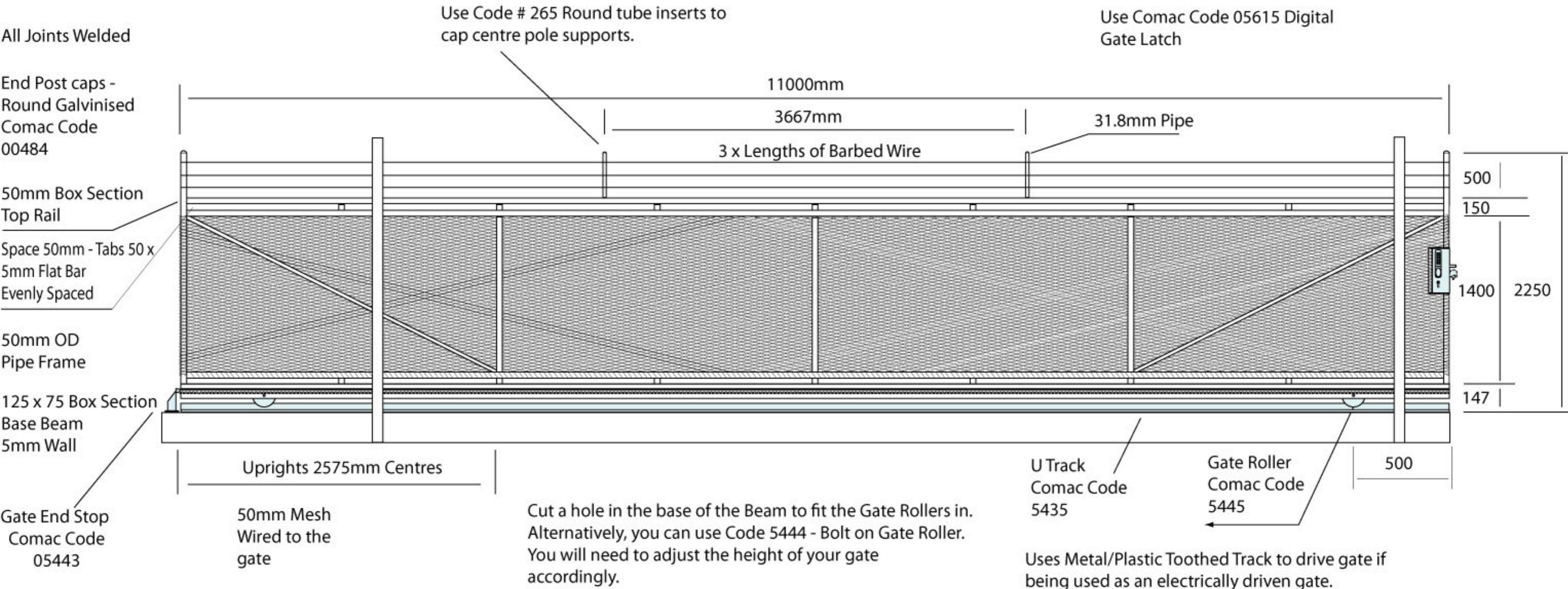

102 - Sliding Gate -Page 1/3
Version 1.0 Completed 21-8-13

**Are you wanting to save time designing?
Ask us to come up with a plan for you!**

Disclaimer: These plans and designs are concepts, accurate to the best of our knowledge. Dimensions and designs shown are based on actual working models, however do not constitute a specification. Co-Mac (PN) Ltd take no responsibility in any form whatsoever for the results of the use of these plans, and the user is recommended to conduct their own assessment of the designs, within the requirements of the application.

www.comac.co.nz
orders@comac.co.nz

PH (06) 350-0015
FAX (06) 354-2662

PH 0800 33 55 22
FAX 0800 42 66 22
105 Kaimanawa Street
PO Box 4 PALMERSTON NORTH 4440



Details

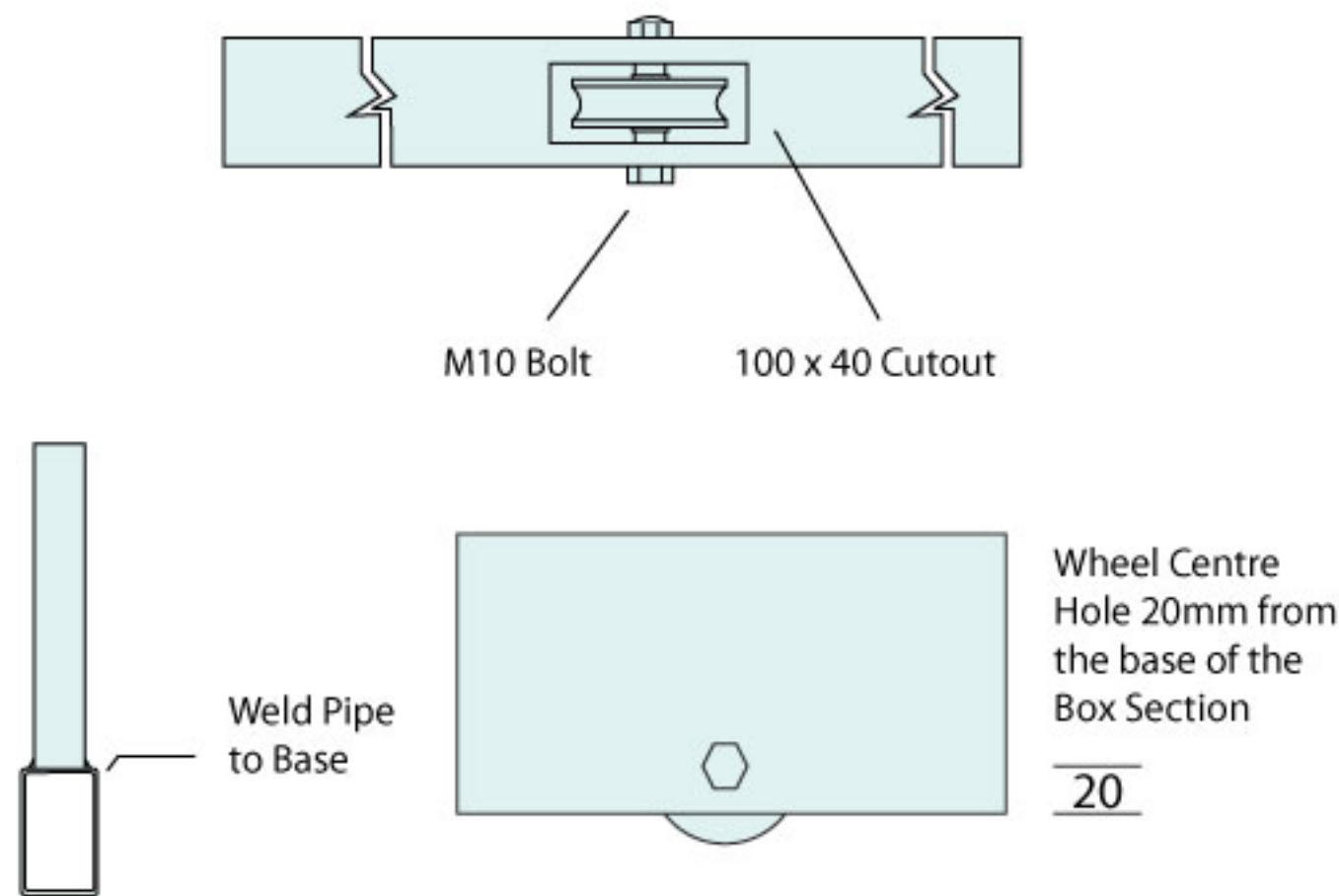

Gate Support Frame



Uses Code 5454 Gate Roller x 2. Rollers are bolted at the same height as the top rail

Box Section Dimensions for Support Frame 65mm x 65mm Square

Gate requires x 2 of the above support frames.

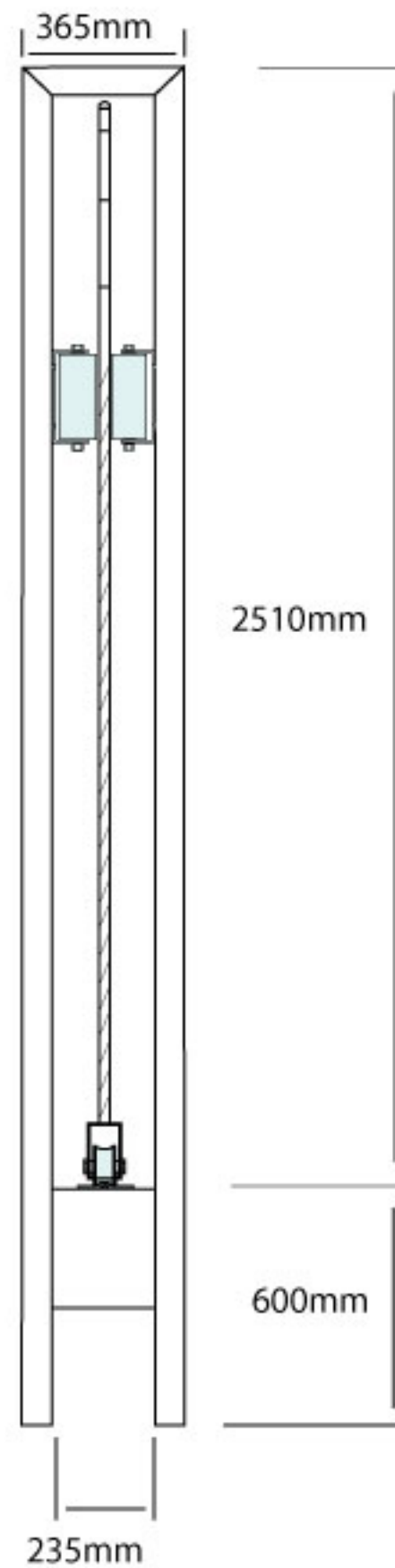

Electric Drive Idea

Notched Drive Track mounted onto 40 x 40 x 5 Right angle. Right Angle bolted to Box Section base.

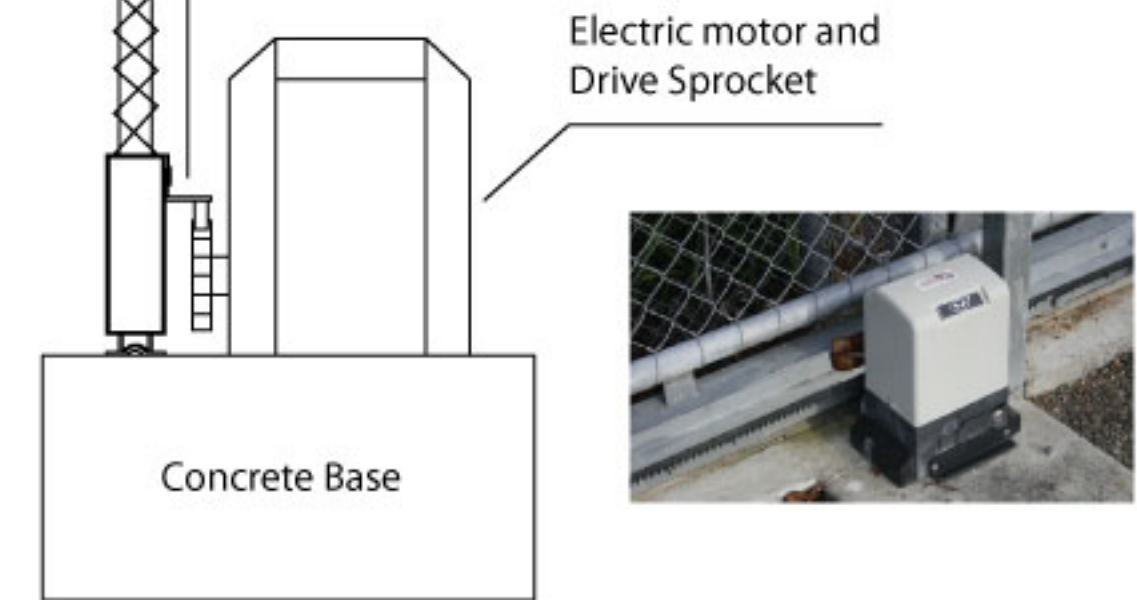

Comac Parts Used

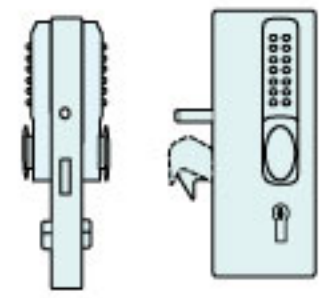

5615 - Digital Gate Latch and Case

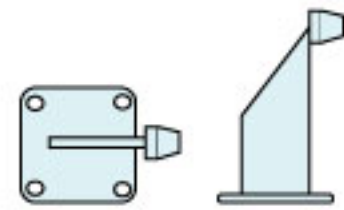

5443 - Gate Stop

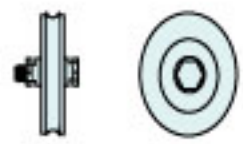

5445 - Gate Roller

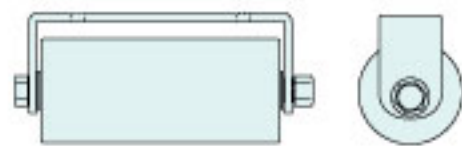

5454 - Support Roller

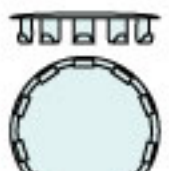

265 Tube Plug



5435 U Track

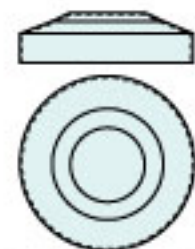

484 Pipe Cap

Gate Latch Detail

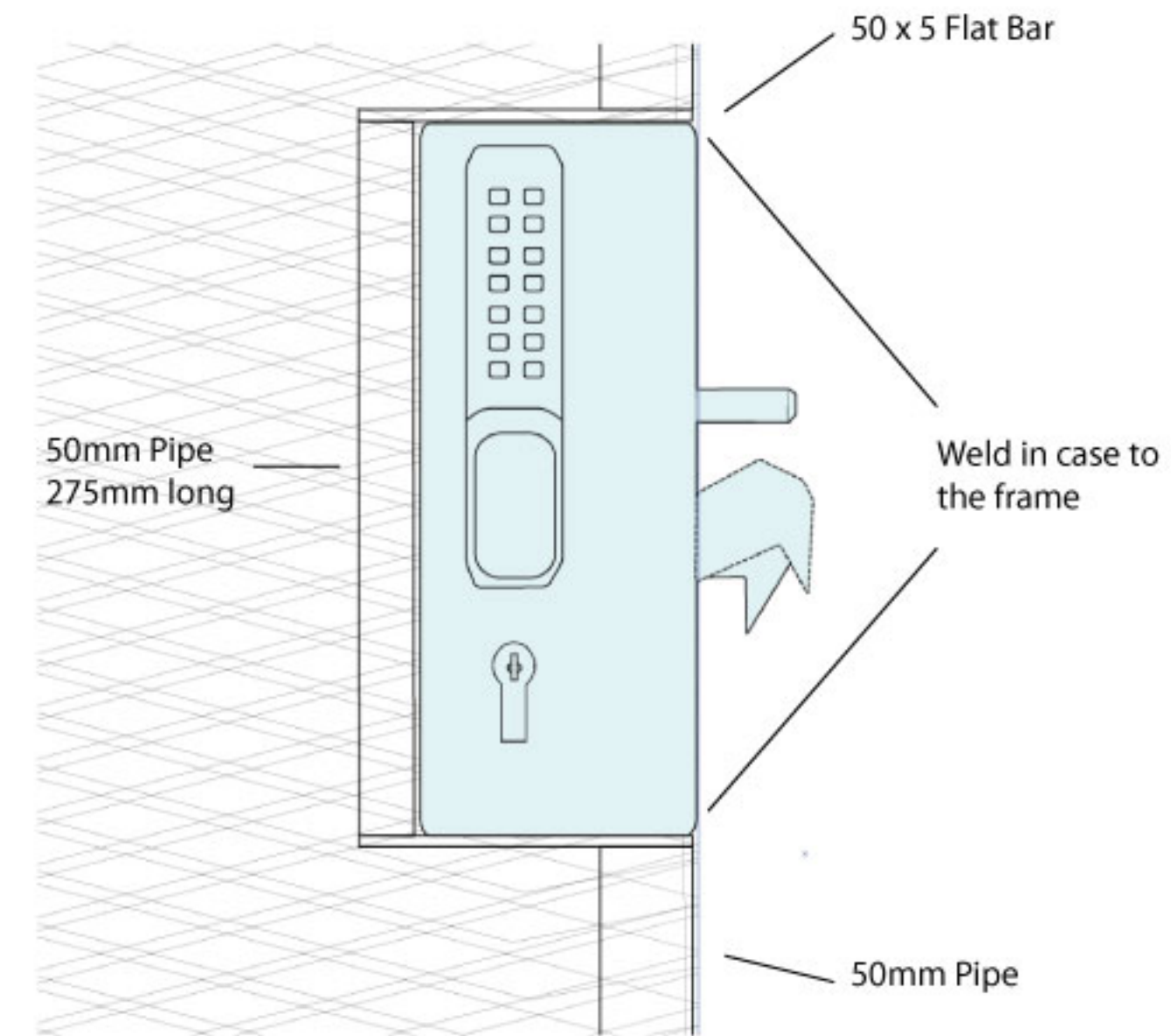

Disclaimer: These plans and designs are concepts, accurate to the best of our knowledge. Dimensions and designs shown are based on actual working models, however do not constitute a specification. Co-Mac (PN) Ltd take no responsibility in any form whatsoever for the results of the use of these plans, and the user is recommended to conduct their own assessment of the designs, within the requirements of the application.

www.comac.co.nz
orders@comac.co.nz

PH (06) 350-0015
FAX (06) 354-2662

PH 0800 33 55 22 105 Kaimanawa Street
FAX 0800 42 66 22 PO Box 4 PALMERSTON NORTH 4440



Are you wanting to save time designing?
Ask us to come up with a plan for you!

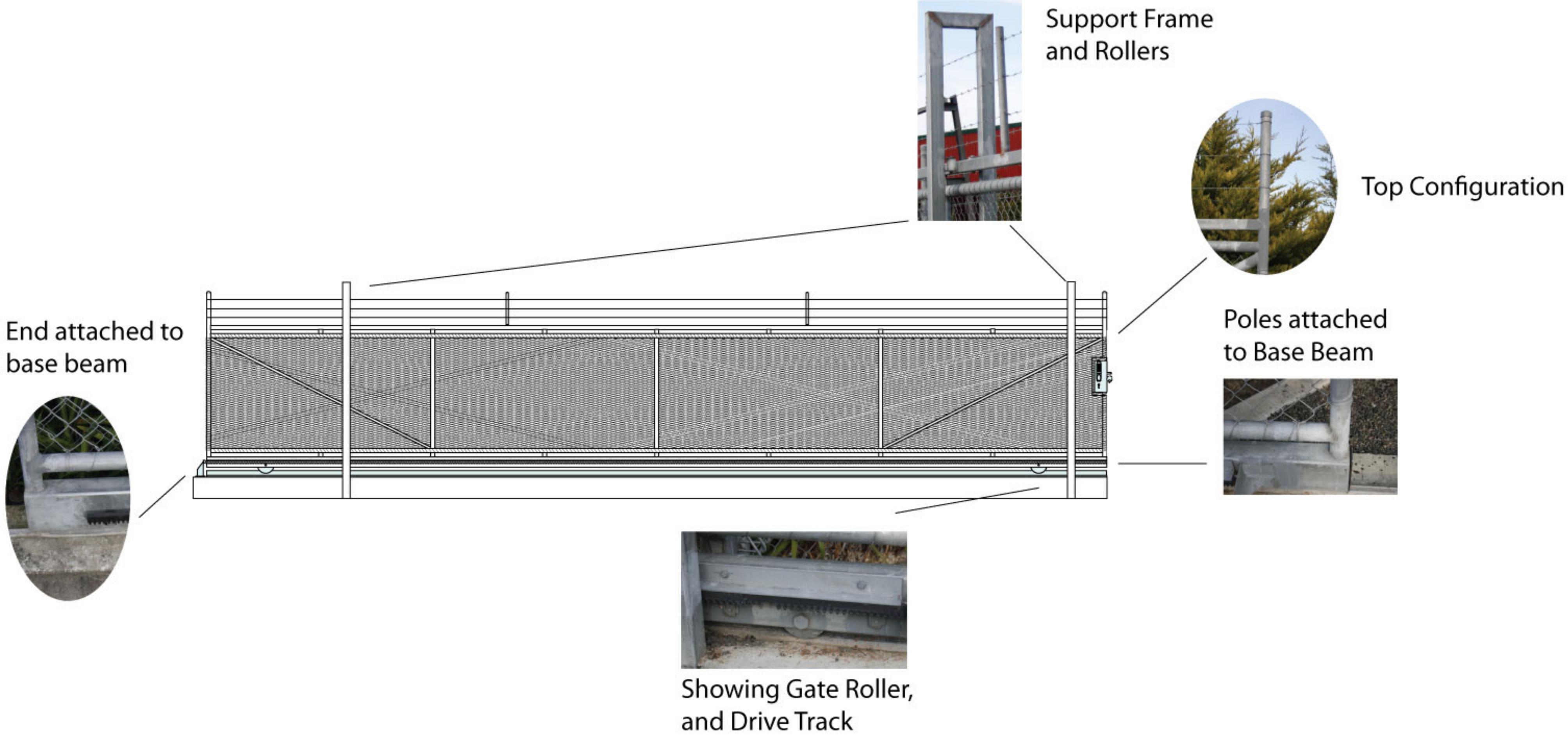

102 - Sliding Gate -Page 3/3
Version 1.0 Completed 21-8-13



FOR HARD TO FIND HARDWARE

Disclaimer: These plans and designs are concepts, accurate to the best of our knowledge. Dimensions and designs shown are based on actual working models, however do not constitute a specification. Co-Mac (PN) Ltd take no responsibility in any form whatsoever for the results of the use of these plans, and the user is recommended to conduct their own assessment of the designs, within the requirements of the application.

www.comac.co.nz
orders@comac.co.nz

PH (06) 350-0015
FAX (06) 354-2662

PH 0800 33 55 22
FAX 0800 42 66 22

105 Kaimanawa Street
PO Box 4 PALMERSTON NORTH 4440

**Are you wanting to save time designing?
Ask us to come up with a plan for you!**

